

JVC

SERVICE MANUAL

CD PORTABLE SYSTEM

RC-BZ5LB/BZ5RD RC-BZ6BU

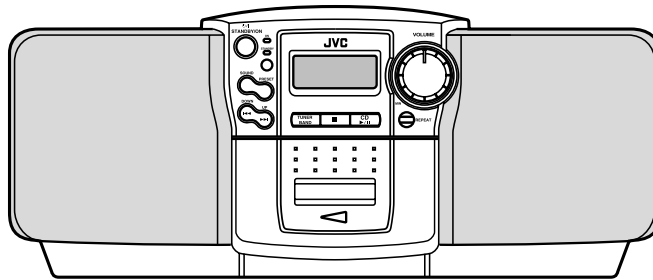
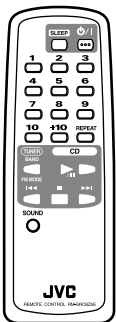

RC-BZ5LB/BZ5RD

Areas suffix	
B	U.K.
E	Continental Europe
EE	Russian Federation
EN	North Europe
EV	Eastern Europe

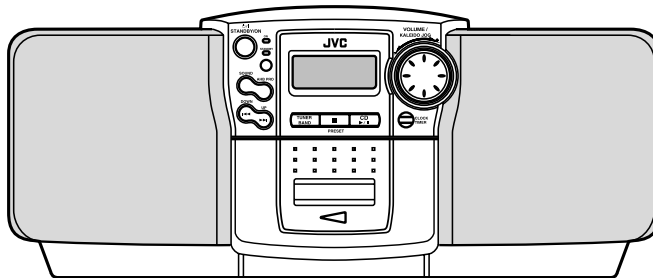
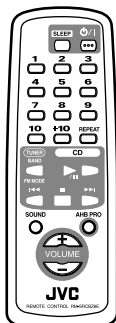

RC-BZ6BU



Contents

Safety precautions	1-2
Important for laser products	1-3
Preventing static electricity	1-4
Disassembly method	1-5
Adjustment method	1-14
Description of major ICs	1-17

Comparison table

Item	RC-BZ5LB/BZ5RD	RC-BZ6BU
Jog dial circuit	Not used	Used
Back light (LCD)	Not used	Used
Bass boost circuit	Not used	Used
Power amplifier	14W	18W
Electrical volume	Not used	Used

Safety precautions

1. This design of this product contains special hardware and many circuits and components specially for safety purposes. For continued protection, no changes should be made to the original design unless authorized in writing by the manufacturer. Replacement parts must be identical to those used in the original circuits. Services should be performed by qualified personnel only.
2. Alterations of the design or circuitry of the product should not be made. Any design alterations of the product should not be made. Any design alterations or additions will void the manufacturer's warranty and will further relieve the manufacture of responsibility for personal injury or property damage resulting therefrom.
3. Many electrical and mechanical parts in the products have special safety-related characteristics. These characteristics are often not evident from visual inspection nor can the protection afforded by them necessarily be obtained by using replacement components rated for higher voltage, wattage, etc. Replacement parts which have these special safety characteristics are identified in the Parts List of Service Manual. Electrical components having such features are identified by shading on the schematics and by (Δ) on the Parts List in the Service Manual. The use of a substitute replacement which does not have the same safety characteristics as the recommended replacement parts shown in the Parts List of Service Manual may create shock, fire, or other hazards.
4. The leads in the products are routed and dressed with ties, clamps, tubings, barriers and the like to be separated from live parts, high temperature parts, moving parts and/or sharp edges for the prevention of electric shock and fire hazard. When service is required, the original lead routing and dress should be observed, and it should be confirmed that they have been returned to normal, after re-assembling.
5. Leakage current check (Electrical shock hazard testing)
After re-assembling the product, always perform an isolation check on the exposed metal parts of the product (antenna terminals, knobs, metal cabinet, screw heads, headphone jack, control shafts, etc.) to be sure the product is safe to operate without danger of electrical shock. Do not use a line isolation transformer during this check.

- Plug the AC line cord directly into the AC outlet. Using a "Leakage Current Tester", measure the leakage current from each exposed metal parts of the cabinet, particularly any exposed metal part having a return path to the chassis, to a known good earth ground. Any leakage current must not exceed 0.5mA AC (r.m.s.)
- Alternate check method
Plug the AC line cord directly into the AC outlet. Use an AC voltmeter having, 1,000 ohms per volt or more sensitivity in the following manner. Connect a 1,500 Ω 10W resistor paralleled by a 0.15 μ F AC-type capacitor between an exposed metal part and a known good earth ground. Measure the AC voltage across the resistor with the AC voltmeter.
Move the resistor connection to each exposed metal part, particularly any exposed metal part having a return path to the chassis, and measure the AC voltage across the resistor. Now, reverse the plug in the AC outlet and repeat each measurement. voltage measured Any must not exceed 0.75 V AC (r.m.s.). This corresponds to 0.5 mA AC (r.m.s.).

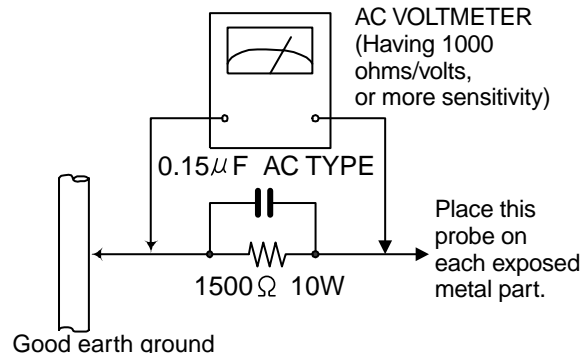

Warning

1. This equipment has been designed and manufactured to meet international safety standards.
2. It is the legal responsibility of the repairer to ensure that these safety standards are maintained.
3. Repairs must be made in accordance with the relevant safety standards.
4. It is essential that safety critical components are replaced by approved parts.
5. If mains voltage selector is provided, check setting for local voltage.

CAUTION Burrs formed during molding may be left over on some parts of the chassis. Therefore, pay attention to such burrs in the case of performing repair of this system.

Important for laser products

1. CLASS 1 LASER PRODUCT

2. DANGER : Invisible laser radiation when open and interlock failed or defeated. Avoid direct exposure to beam.

3. CAUTION : There are no serviceable parts inside the Laser Unit. Do not disassemble the Laser Unit. Replace the complete Laser Unit if it malfunctions.

4. CAUTION : The compact disc player uses invisible laserradiation and is equipped with safety switches which prevent emission of radiation when the drawer is open and the safety interlocks have failed or are defeated. It is dangerous to defeat the safety switches.

5. CAUTION : If safety switches malfunction, the laser is able to function.

6. CAUTION : Use of controls, adjustments or performance of procedures other than those specified herein may result in hazardous radiation exposure.

 **CAUTION** Please use enough caution not to see the beam directly or touch it in case of an adjustment or operation check.

VARNING : Osynlig laserstrålning är denna del är öppnad och spärren är urkopplad. Betrakta ej strålen.

VARO : Avattaessa ja suojalukitus ohitettaessa olet alttiina näkymättömälle lasersäteilylle. Älä katso säteeseen.

ADVARSEL : Usynlig laserstråling ved åbning , når sikkerhedsafbrydere er ude af funktion. Undgå udsættelse for stråling.

ADVARSEL : Usynlig laserstråling ved åpning, når sikkerhetsbryteren er avslott. unngå utsettelse for stråling.

REPRODUCTION AND POSITION OF LABELS

WARNING LABEL

CLASS 1
LASER PRODUCT



Preventing static electricity

1. Grounding to prevent damage by static electricity

Electrostatic discharge (ESD), which occurs when static electricity stored in the body, fabric, etc. is discharged, can destroy the laser diode in the traverse unit (optical pickup). Take care to prevent this when performing repairs.

2. About the earth processing for the destruction prevention by static electricity

Static electricity in the work area can destroy the optical pickup (laser diode) in devices such as CD players. Be careful to use proper grounding in the area where repairs are being performed.

2-1 Ground the workbench

Ground the workbench by laying conductive material (such as a conductive sheet) or an iron plate over it before placing the traverse unit (optical pickup) on it.

2-2 Ground yourself

Use an anti-static wrist strap to release any static electricity built up in your body.

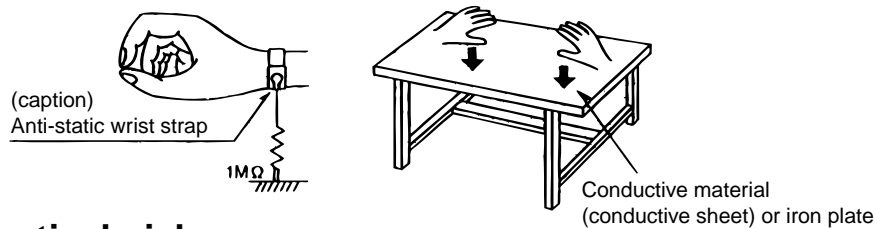

3. Handling the optical pickup

1. In order to maintain quality during transport and before installation, both sides of the laser diode on the replacement optical pickup are shorted. After replacement, return the shorted parts to their original condition. (Refer to the text.)
2. Do not use a tester to check the condition of the laser diode in the optical pickup. The tester's internal power source can easily destroy the laser diode.

4. Handling the traverse unit (optical pickup)

1. Do not subject the traverse unit (optical pickup) to strong shocks, as it is a sensitive, complex unit.
2. Remove solder of the land on the flexible cable after replacing the optical pickup. For specific details, refer to the replacement procedure in the text. Remove the anti-static pin when replacing the traverse unit. Be careful not to take too long a time when attaching it to the connector.
3. Handle the flexible cable carefully as it may break when subjected to strong force.
4. It is not possible to adjust the semi-fixed resistor that adjusts the laser power. Do not turn it

Attention when traverse unit is decomposed

***Please refer to "Disassembly method" in the text for pick-up and how to detach the substrate.**

1. Short the land before the card wire is removed from connector on the Main board as shown in Figure.
(When the wire is removed without putting up solder, the CD pick-up assembly might destroy.)
2. Please remove solder after connecting the card wire with when you install picking up in the substrate.

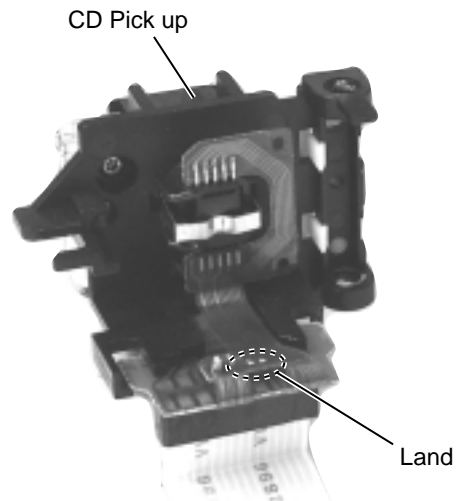

Disassembly method

<Main body>

■ Removing the front cabinet assembly / rear cabinet assembly (See Fig.1 to 3)

1. Detach the battery cover on the back of the body. Remove the eight screws A attaching the front cabinet assembly and the rear cabinet assembly.
2. Press STOP / EJECT button on the upper side of the body to open the cassette door.
3. Remove the front cabinet assembly toward the front and pull out the volume knob at the same time.
4. Disconnect the speaker harness from connector CN309 on the main board in the rear cabinet assembly.

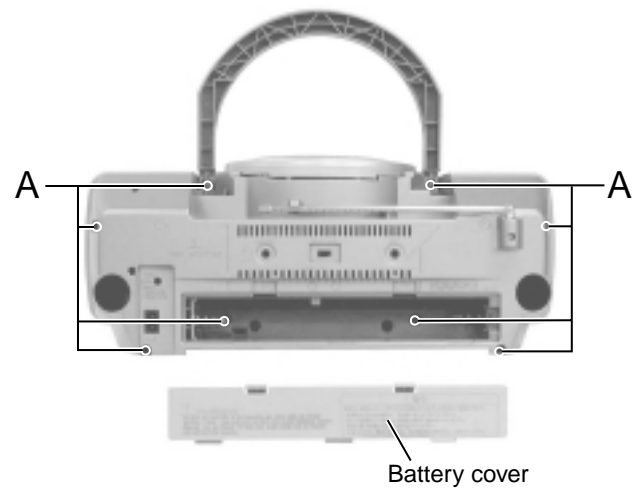

Fig.1

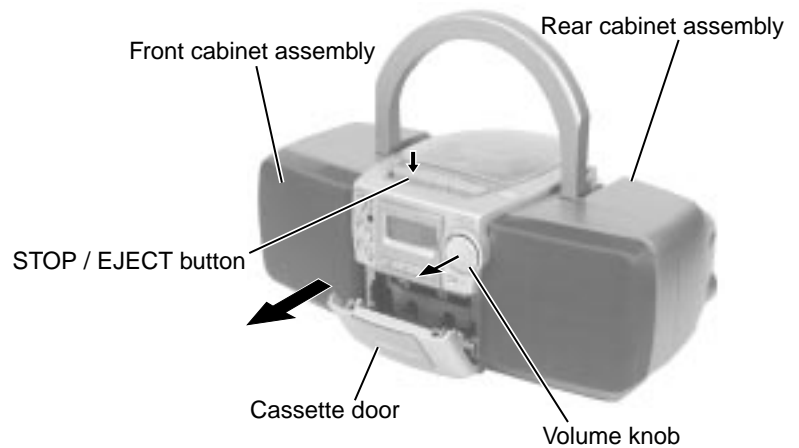

Fig.2

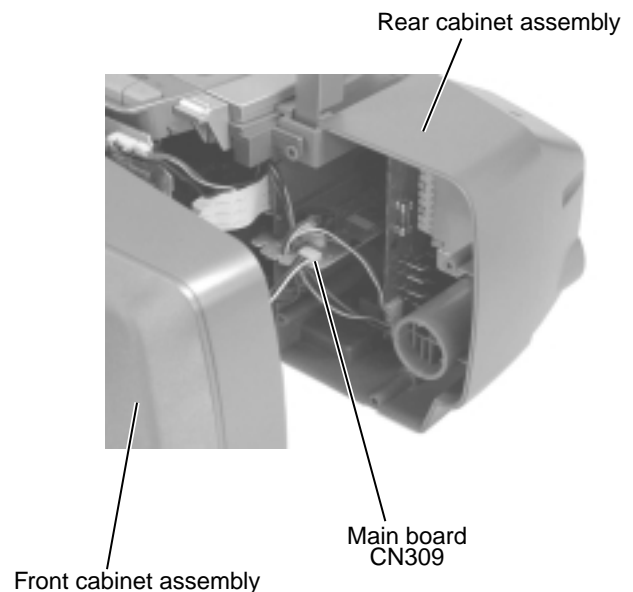

Fig.3

<Front cabinet assembly>

**■Removing the speaker (L) and (R)
(See Fig.4)**

• Prior to performing the following procedure, remove the front cabinet assembly.

1. Remove the eight screws B in the front cabinet.

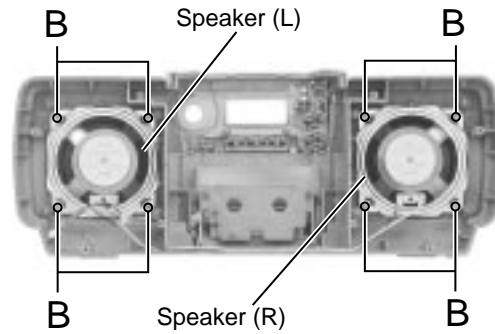

Fig.4

**■Removing the cassette door
(See Fig.5 and 6)**

• Prior to performing the following procedure, remove the front cabinet assembly.

1. Remove the door spring in the front cabinet assembly.
2. Insert a screwdriver between the door arm and the front cabinet and slide the door arms inward, then detach the cassette door from the front cabinet.

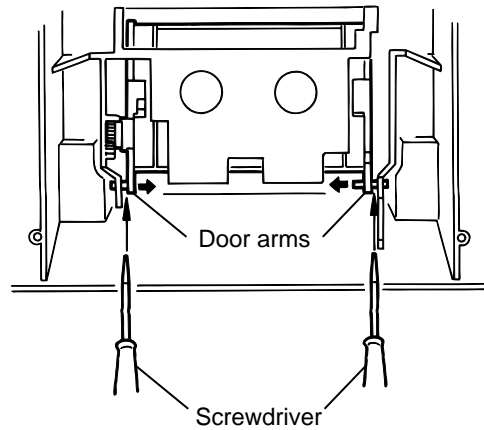

Fig.5

※Reattaching the door spring

1. Reattach the door spring to the cassette door shaft with opening the cassette door.
2. Fit another end of the door spring to the front cabinet rib.
3. Fit the shorter end of the door spring to the cassette door.

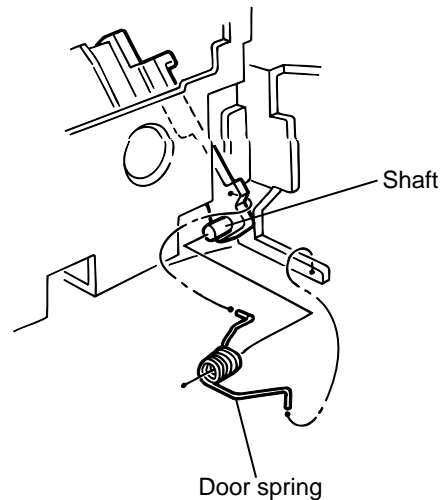

Fig.6

<Rear cabinet assembly>

■ Removing the CD / cassette and amplifier assembly from the rear cabinet (See Fig.7 and 8)

• Prior to performing the following procedure, remove the front cabinet assembly and the rear cabinet assembly.

1. For the harness connecting the amplifier board with the power board, disconnect it from connector CN306 on the power board in the right rear cabinet assembly. For the harness connecting the battery terminal wire with the power board, disconnect it from CN307 on the power board.
2. Remove the two screws C on the bottom of the cassette mechanism unit.
3. Release the harnesses from the slot a, b and c and the notch of the main board in the rear cabinet.
4. Remove the CD / cassette and amplifier assembly from the rear cabinet.

※ Now the CD / cassette and amplifier assembly is ready to conduct burn-in.

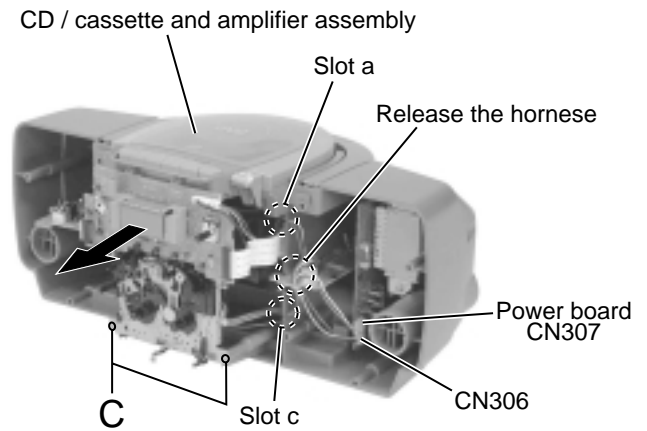

Fig.7

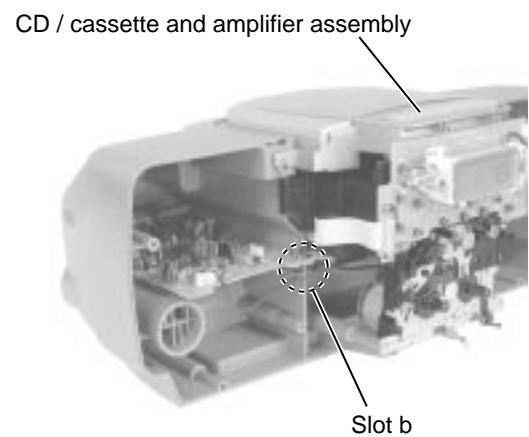

Fig.8

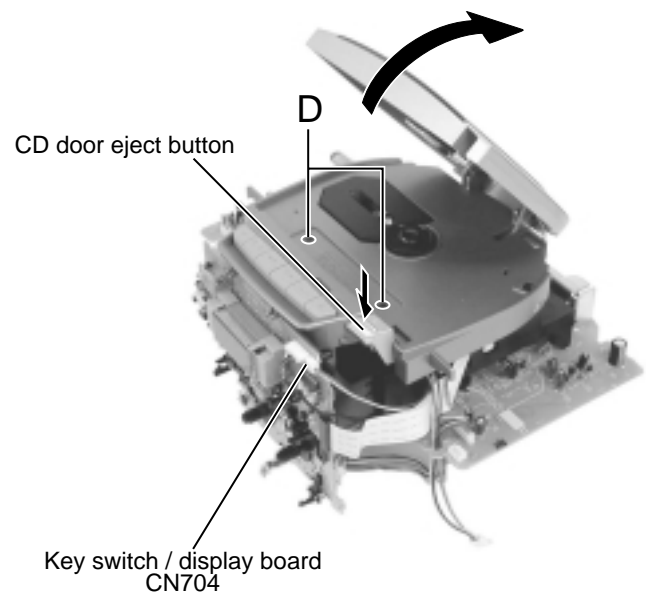

Fig.9

■Removing the CD cover and door unit
(See Fig.9 and 10)

- Prior to performing the following procedure, remove the CD / cassette and amplifier assembly.
1. Disconnect the harness from connector CN704 on the key switch / display board (The harness is extending from the door switch board).
 2. Press EJECT button to open the CD door.
 3. Remove the two screws D on the front of the CD cover and door unit.
 4. Raise the front part of the CD cover and door unit and detach upward. Then push the whole unit backward until it comes off.

ATTENTION: At this point, the CD mechanism unit will become removable. So handle the rear cabinet with care.

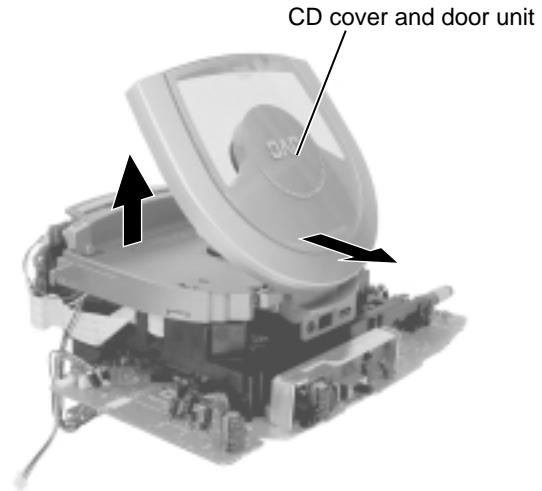

Fig.10

■Removing the CD door switch board
(See Fig.11)

- Prior to performing the following procedure, remove the CD cover and door unit.
1. Turn over the CD cover and door unit and gently spread apart the locking tab. Then remove the CD door switch board in the direction of the arrow while releasing it from joint d.

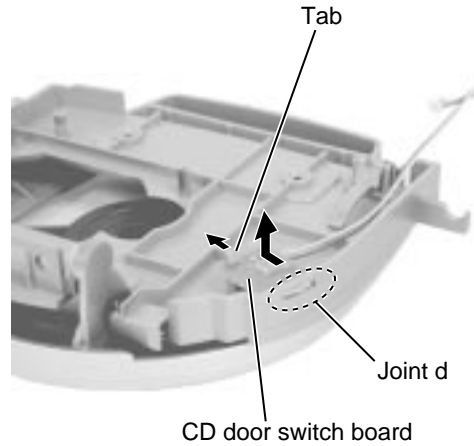

Fig.11

■Removing the key switch / display board
(See Fig.12)

- Prior to performing the following procedure, remove the front cabinet assembly and the rear cabinet assembly.
1. Disconnect the card wires from connector CN701, CN702 and CN703, then the harness from CN704 on the key switch / display board.
 2. Remove the four screws E attaching the key switch / display board.
 - ※The key switch / display board can be removed even if the mechanism cover is attached.

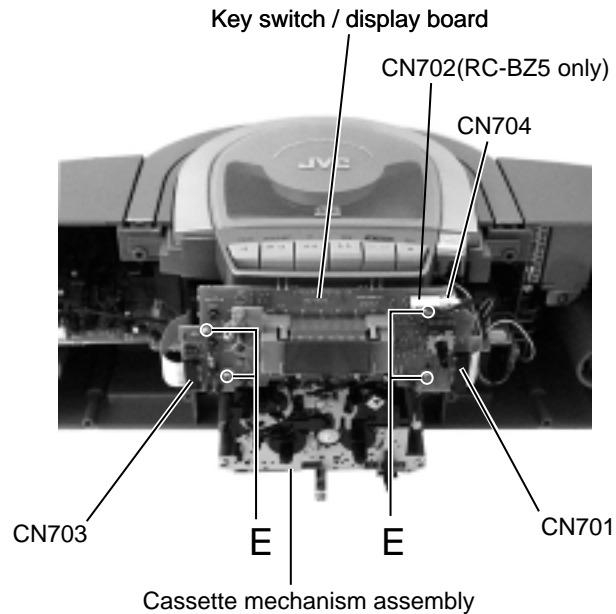

Fig.12

■Removing the cassette mechanism assembly (See Fig.13 to 15)

- Prior to performing the following procedure, remove the CD / cassette and amplifier assembly, the CD cover and door unit and disconnect the harnesses connected to the key switch / display board.
 - The cassette mechanism cover is still attached.
1. Push inward the locking tabs e on both sides of the cassette mechanism cover and remove the mechanism cover in the direction of the arrow.
 2. Disconnect the harnesses from connector CN301 and CN308 on the main board.
 3. Remove the upper two screws F and the cassette mechanism assembly toward the front.

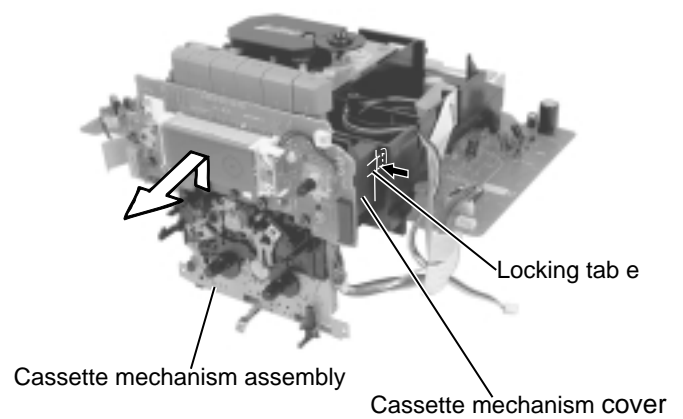

Fig.13

■Removing the CD mechanism assembly (See Fig.16)

- Prior to performing the following procedure, remove the CD / cassette and amplifier assembly, the CD cover and door unit.
1. Disconnect the harness from connector P011 on the motor board in the lower part of the CD mechanism assembly. Then disconnect the pickup card wire from CN601 on the main board.
 2. Remove the CD mechanism assembly upward.

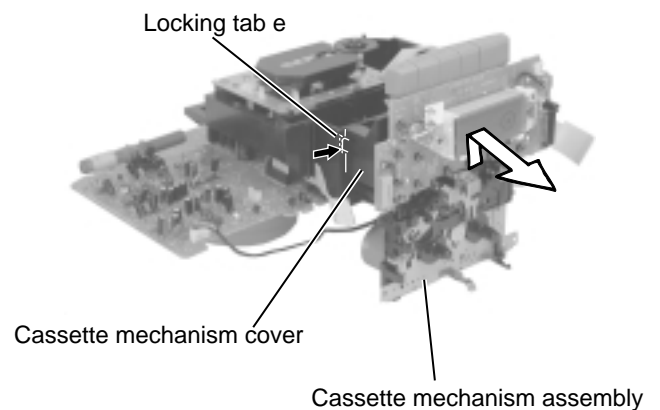

Fig.14

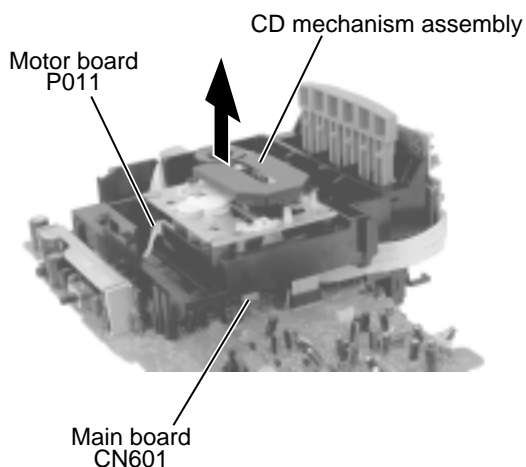

Fig.16

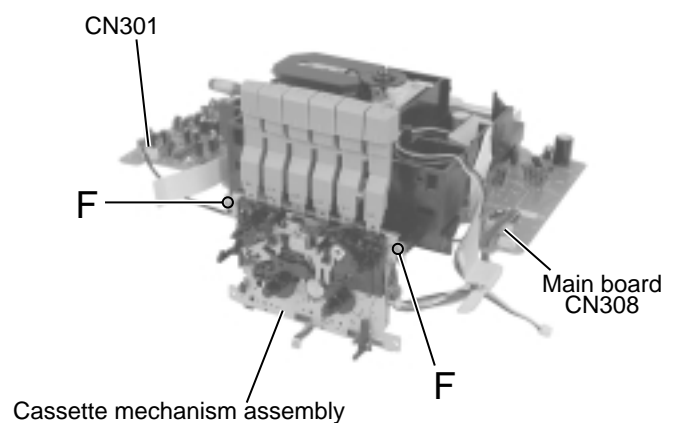

Fig.15

■Removing the main board (See Fig.17 to 19)

• Prior to performing the following procedure, remove the CD / cassette and amplifier assembly, the CD cover and door unit and the CD mechanism assembly.

1. Disconnect the harnesses from connector CN301 and CN308 on the main board (The harnesses are extending from the cassette mechanism assembly).
2. Disconnect the harness from connector CN702 on the key switch/display board (RC-BZ5 only).
3. Remove the two screws G on the underside of the main board and release the two joint tabs f from the chassis in the direction of the arrow.

ATTENTION: When reassembling, get the harness extending from FW301 and FW302 on the main board through the two slots g of the chassis. Get the card wire extending from CN304 on the main board through the hook h and the slot i.

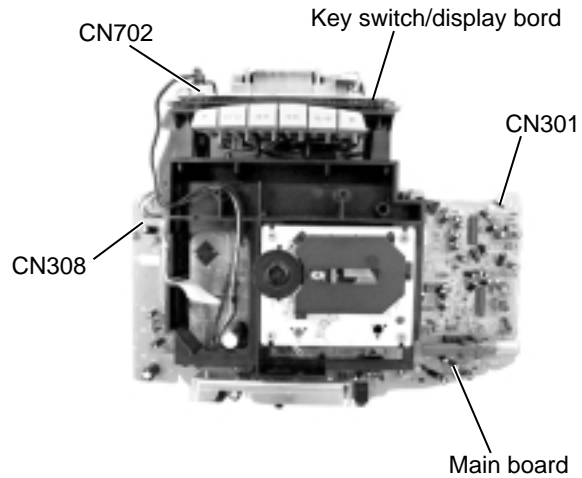

Fig.17

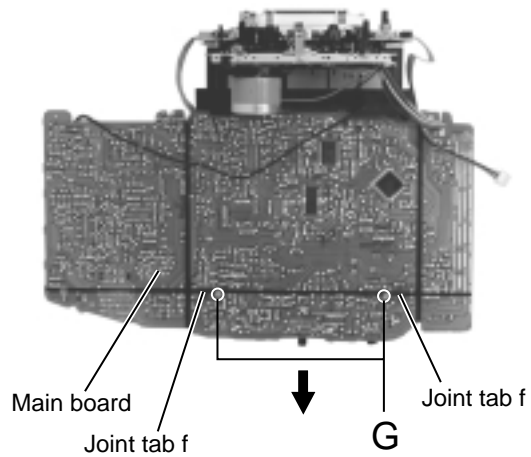

Fig.18

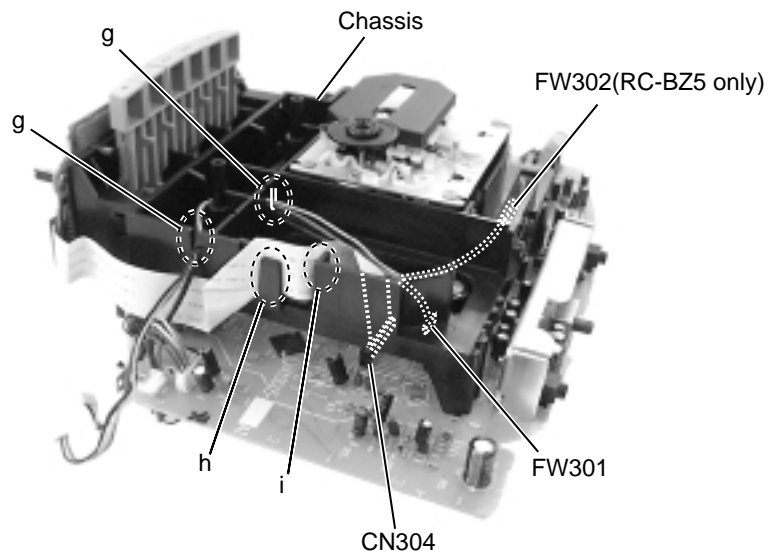

Fig.19

■Removing the power transformer assembly (See Fig.20)

- Prior to performing the following procedure, remove the front cabinet assembly and the rear cabinet assembly.

1. Disconnect the harnesses from connector CN306 and CN307 on the power board in the power transformer assembly.
2. Remove the two screws H attaching the AC jack of the power board and the two screws I attaching the power transformer. Remove the power transformer assembly toward the front.

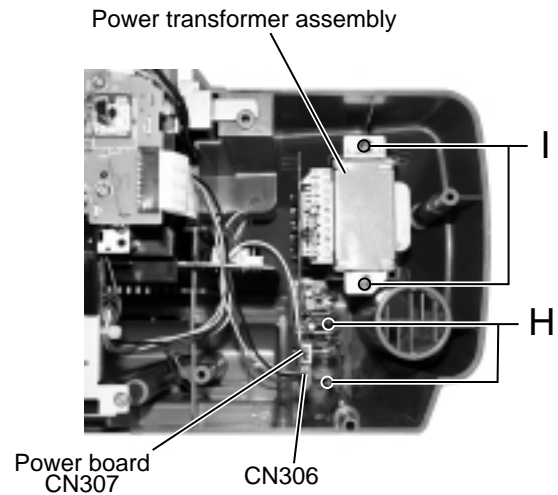

Fig.20

■Removing the battery board (See Fig.21 and 22)

- Prior to performing the following procedure, remove the front cabinet assembly and the rear cabinet assembly.

1. Disconnect the battery terminal wire from connector CN307 on the power board.
2. Remove the battery board on the back of the rear cabinet.

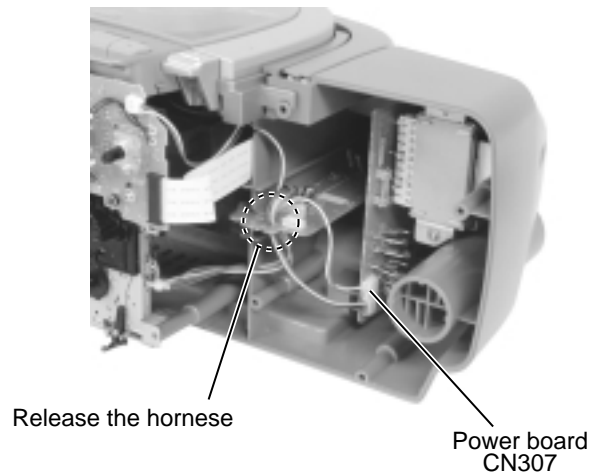

Fig.21

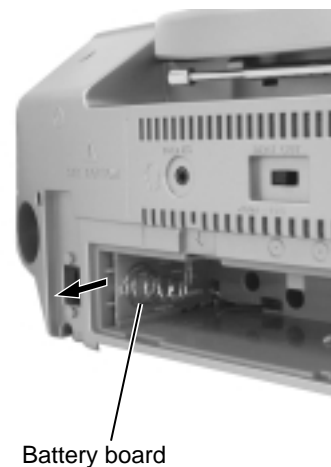

Fig.22

<Cassette mechanism section>

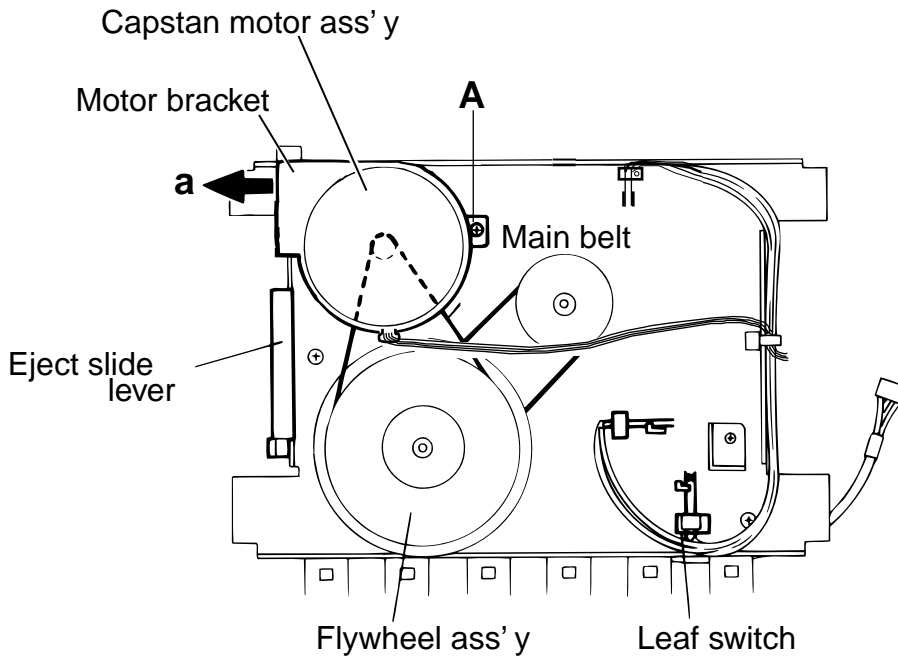

Fig.1

■ **Capstan motor** (Fig.1)

1. Remove the cassette mechanism assembly. (Refer to the article "Cassette mechanism assembly" appearing on a previous page.)
2. Remove one screw A retaining the capstan motor assembly from the back of the cassette mechanism assembly.
3. Disengage the main belt from the flywheel assembly. Then slide the capstan motor slightly in the direction of the arrow a while lifting it upwards to remove together with the main belt.

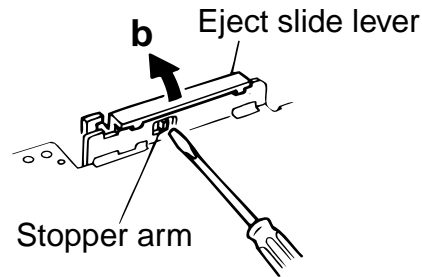

Fig.2

■ **Eject slide lever** (Fig.2)

1. Place the cassette mechanism back side frontward and disengage the stopper arm b of the Eject slide lever by pressing it inwards through the opening of the chassis with a small screwdriver as shown in Fig.2.

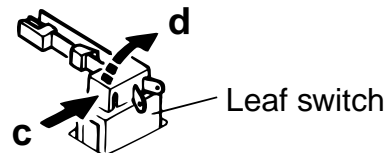

Fig.3

■ **Leaf switch** (Fig.3)

1. Press the leaf switch in the direction of the arrow c and then remove it in the direction of the arrow d referring to Fig.3.

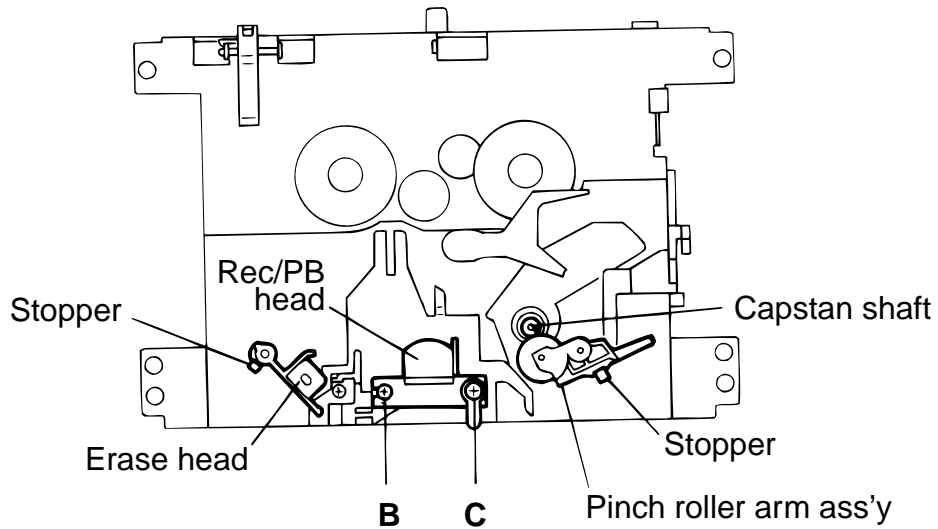

Fig.4

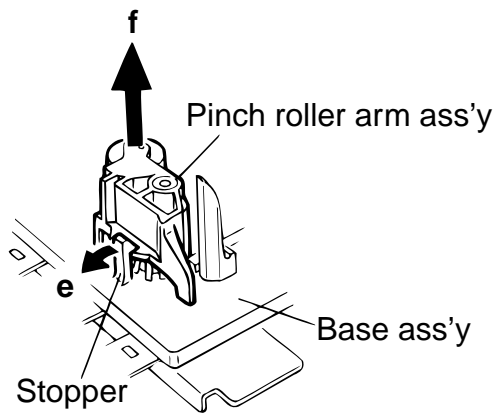

Fig.5

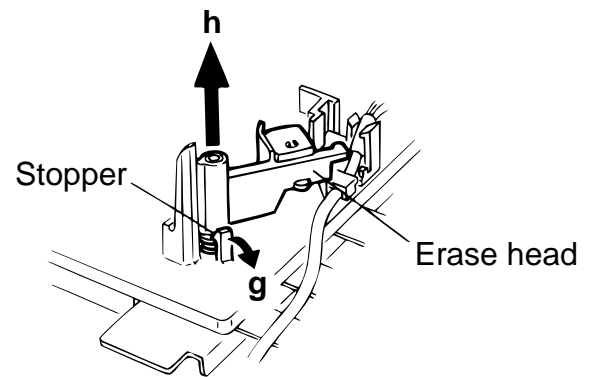

Fig.6

■ **Pinch roller arm assembly** (Fig.4 to 5)

1. Pull out the stopper protruding from the base assembly in the direction of the arrow e to remove it from the pinch roller arm assembly.
2. Then, pull out the pinch roller arm assembly in the direction of the arrow f.

■ **Rec/PB head and erase head** (Fig.4 to 6)

1. Remove two screws B, C retaining the Rec/PB head.
2. Pull out the stopper of the erase head in the direction of the arrow g.
3. Pull out the erase head in the direction of the arrow h.

■ **Flywheel assembly** (Fig.7)

1. Remove the split washer retaining the flywheel assembly in the direction of the arrow i.
2. Pull the flywheel assembly out of the back side of the cassette mechanism assembly in the direction of the arrow j.

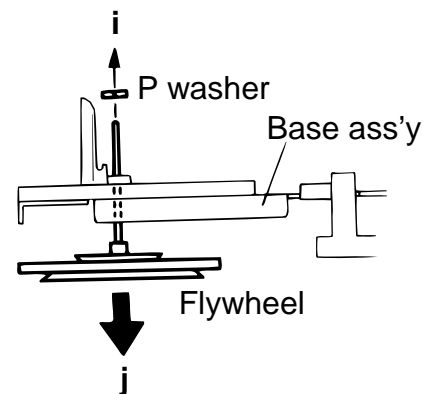

Fig.7

■ **Cassette amplifier section**

Item	Conditions	Adjustment & Confirmation Method	Standard Value	Adjusting Point
Head azimuth adjustment	<ul style="list-style-type: none"> • Test tape: VT702(8 kHz) • Test output from: Speaker terminal (with 3 Ω load) 	<ol style="list-style-type: none"> 1. Play back the test tape VT702 (8 kHz signal). 2. Adjust the azimuth adjusting screw so that phase difference between R and L channels is minimum with the output level that is the maximum level plus less than 2 dB in the FWD and REV mode. After the adjustment apply screw sealant onto the azimuth adjusting screw for more than half the screw head. 3. If the head azimuth is still maladjusted, re-adjust it with the azimuth adjusting screw alternately in the FWD and REV modes. 	<ul style="list-style-type: none"> • Output: Max. level plus less than 2 dB • Phase difference between R & L ch: Minimum 	Azimuth adjusting screw (after head replacement only)
Tape speed, Wow & flutter check	<ul style="list-style-type: none"> • Function selector: TAPE • Test tape: VT712 (3 kHz) • Test output from: Speaker terminal (with 3 Ω load) 	<ol style="list-style-type: none"> 1. Play back the end portion of the test tape VT712 (3 kHz signal). 2. At that time check to see if the frequency counter reads 2940 to 3090 Hz. If not, adjust the semi-fixed resistor inside the motor to obtain the specified frequency. 3. Wow and flutter must be 0.38 % or less (unweighted). 	Frequency: 2940-3090 Hz 0.38 % or less (unweighted)	Tape speed (with semi-fixed resistor inside motor)
Playback output check	<ul style="list-style-type: none"> • Function selector: TAPE • Test tape: VT722, VT724 (1 kHz) • Test output from: Speaker terminal (with 3 Ω load) 	<ol style="list-style-type: none"> 1. With the test tape VT722 (1 kHz signal) being played back, confirm that the speaker output is 2.1 W or more with 10 % distortion. 2. With the test tape VT724 being played back, confirm that the deviation between R-ch and L-ch outputs is less than 3 dB. 	<ul style="list-style-type: none"> • Speaker output with 10 % distortion: 2.1W or more • Deviation between R & L ch outputs: 3 dB or less 	
Playback frequency response check	<ul style="list-style-type: none"> • Function selector: TAPE • Test tape: VT738 • Test output from: Speaker terminal (with 3 Ω load) 	With the test tape VT738 being played back, confirm that the deviation between 1 kHz and 125 Hz signals is 6 ± 3 dB and that between the 1 kHz and 8 kHz signals is 0 ± 4 dB.	<ul style="list-style-type: none"> • Deviation between 1 kHz & 125 Hz: 6 ± 3 dB • Deviation between 1 kHz & 8 kHz: 0 ± 4 dB 	
REC/PB sensitivity check	<ul style="list-style-type: none"> • Function selector: TAPE • Mode: Recording • Test input to: CN301 	With the input of 1 kHz, -20 dBs signal to the test point CN301, confirm that the level difference between the recording and playback is 0 ± 3 dB or less.	<ul style="list-style-type: none"> • Level difference between REC & PB: 0 ± 3 dB or less 	

■ Tuner sections

Item	Conditions	Adjustment & Confirmation Methods	Stand. values	Adjust
FM, AM IF adjustment MPX adjustment FM tracking adjustment		☆ Since a solid IF is being used, no adjustment is required. ☆ Since a ceramic resonator is being used, no adjustment is required. ☆ Since a fixed coil is being used, no adjustment is required.		

Description of major ICs

■ MN35510 (IC603) : Digital servo & digital signal processor

1. Block diagram

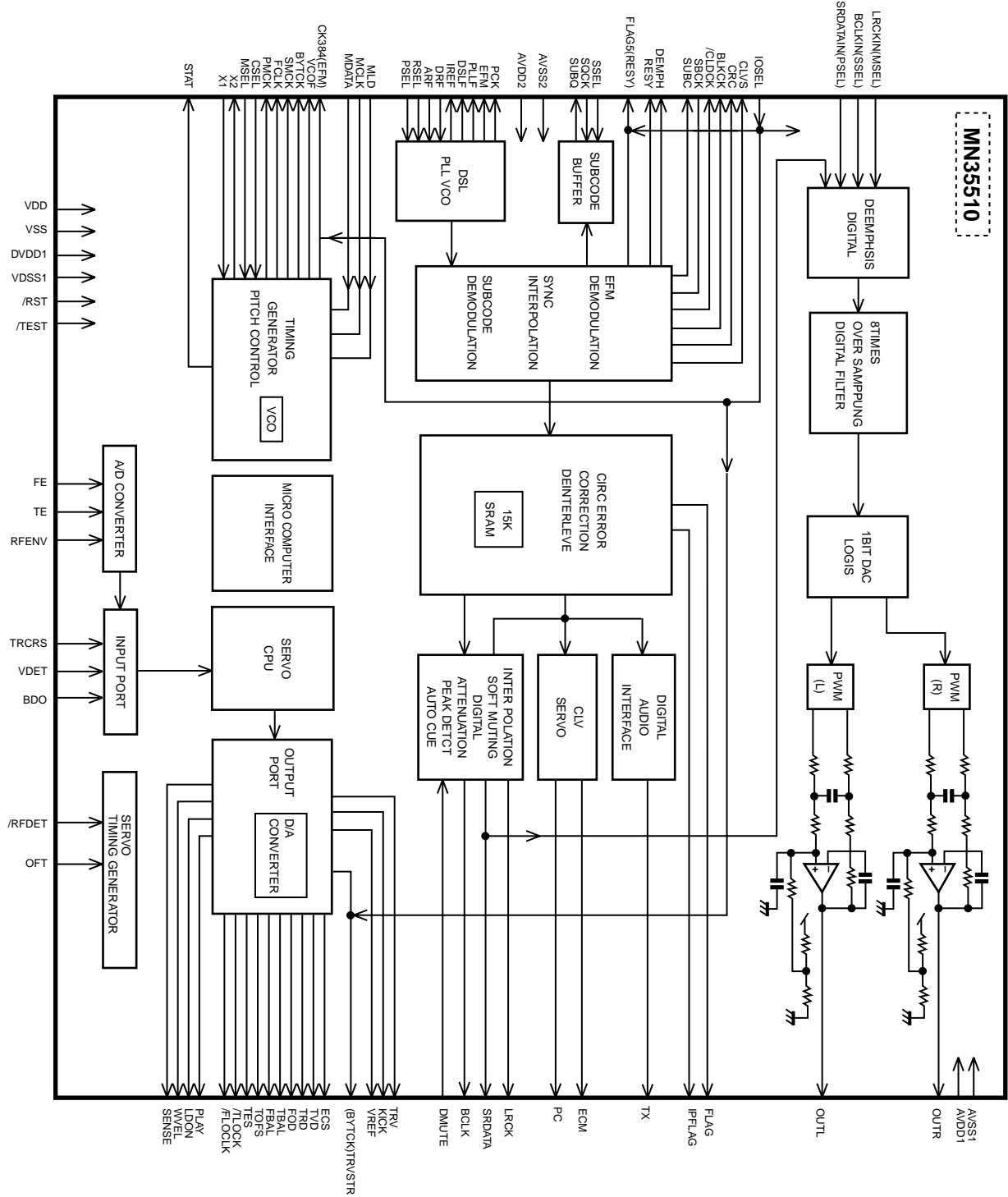

■ BA6897FP (IC602) : 4channel driver

1. Terminal layout & Block diagram

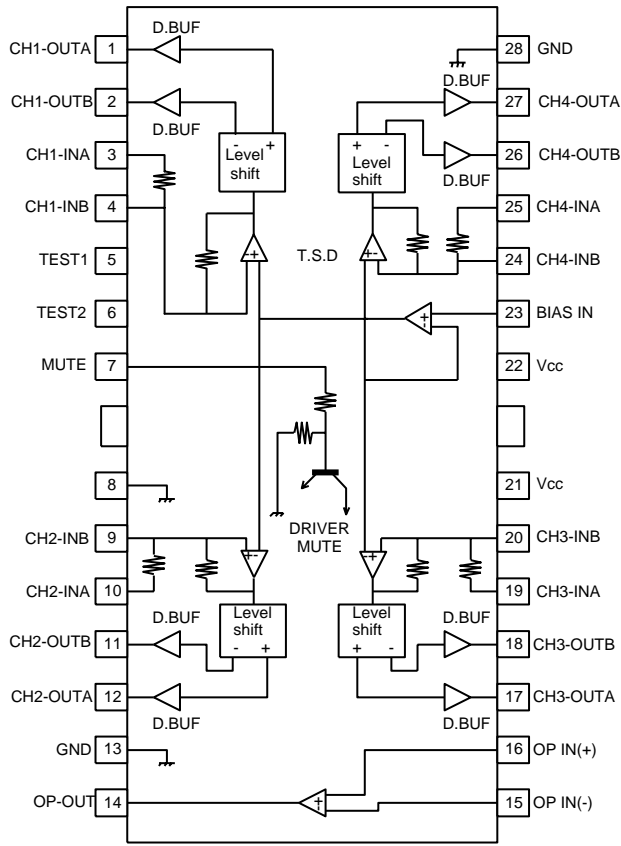

■ LC72136N (IC2) : PLL Frequency synthesizer

1. Terminal layout

XT	1	22	XT
FM/AM	2	21	GND
CE	3	20	LPFOUT
DI	4	19	LPFIN
CLOCK	5	18	PD
DO1	6	17	VCC
FM ST VCO_STOP	7	16	FMIN
AM/FM	8	15	AMIN
NC	9	14	NC
NC	10	13	IFCONT
SDIN	11	12	IFIN

2. Block diagram

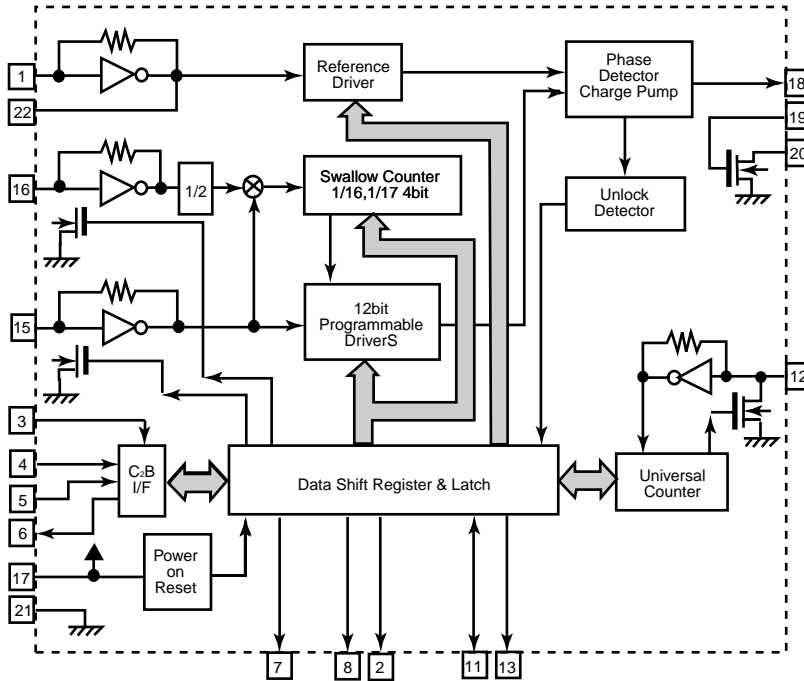

3. Pin function

Pin No.	Symbol	I/O	Function	Pin No.	Symbol	I/O	Function
1	XT	I	X'tal oscillator connect (75KHz)	12	IFIN	I	IF counter signal input
2	FM/AM	O	LOW:FM mode (Not use)	13	IFCONT	O	IF signal output
3	CE	I	When data output/input for 4pin(input) and 6pin(output): H	14	NC	-	Not use
4	DI	I	Input for receive the serial data from controller	15	AMIN	I	AM Local OSC signal output
5	CLOCK	I	Sync signal input use	16	FMIN	I	FM Local OSC signal input
6	DO1	O	Data output for Controller Output port	17	VCC	-	Power supply(VDD=4.5~ 5.5V) When power ON:Reset circuit move
7	FM ST VCO_STOP	O	"Low": MW mode	18	PD	O	PLL charge pump output(H: Local OSC frequency Height than Reference frequency. L: Low Agreement: Height impedance)
8	AM/FM	O		19	LPFIN	I	Input for active lowpassfilter of PLL
9	NC	-	Not use	20	LPFOUT	O	Output for active lowpassfilter of PLL
10	NC	-	Not use	21	GND	-	Connected to GND
11	SDIN	I/O	Data input/output (Not use)	22	XT	I	X'tal oscillator(75KHz)

■ TA2104AN (IC1) : AM/FM 1 chip tuner IC

1. Terminal layout & Block diagram

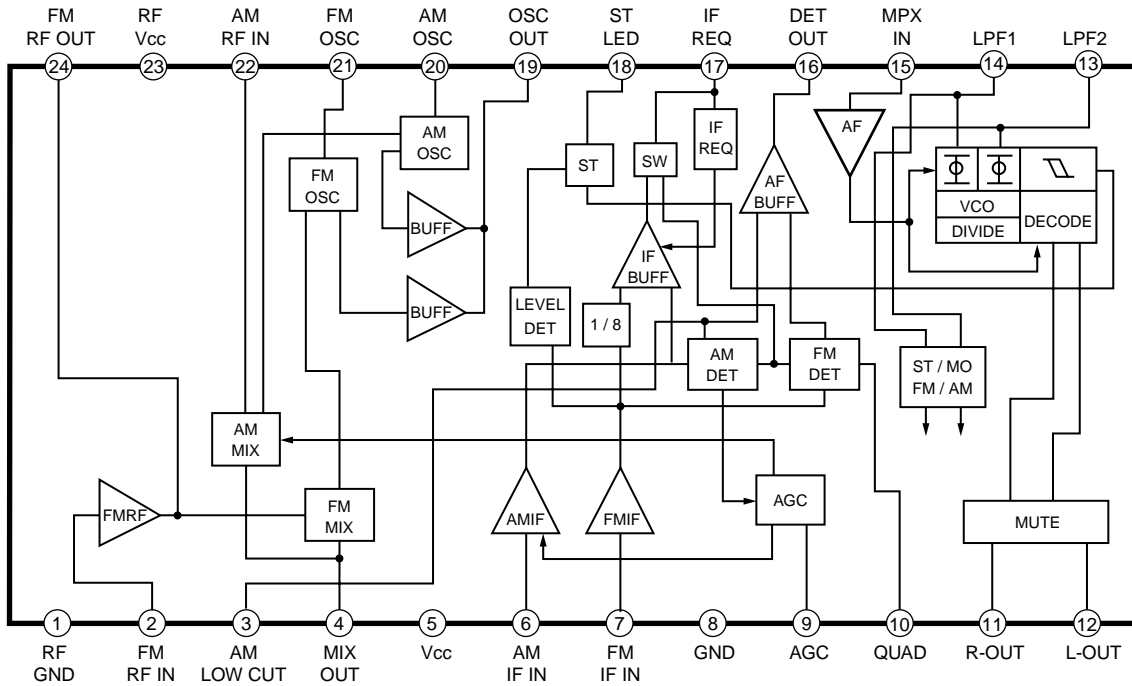

2. Pin function

Pin	Pin Name	Function
1	RF GND	RF Stage ground
2	FM RF IN	FM RF Input
3	AM LOW CUT	AM Low Frequency Cut Filter External Component
4	MIX OUT	Mixer Output
5	Vcc	Power Supply
6	AM IF IN	AM IF Amplifier Input
7	FM IF IN	FM IF Amplifier Input
8	GND	Ground
9	AGC	AM AGC External Capacitor
10	QUAD	FM Quadrature Detector Terminal
11	R-OUT	Audio output CH-R
12	L-OUT	Audio output CH-L
13	LPF2	LPF Terminal for Phase Detector / AM, FM Switching
14	LPF1	LPF Terminal for Synchronous Detector / VCO Stop
15	MPX IN	FM MPX Input
16	DET OUT	AM/FM Detector Output
17	IF REQ	IF Output / IF Request control
18	ST LED	FM Stereo Indicator Output
19	OSC OUT	Local Oscillator Output
20	AM OSC	AM Oscillator
21	FM OSC	FM Oscillator
22	AM RF IN	AM RF Input
23	RF Vcc	RF Stage Vcc
24	FM RF OUT	FM RF Amplifier Output

■ AN8806SB (IC601) : RF & Servo amplifier

1. Terminal layout

PD	1	36	PDAC
LD	2	35	PDBD
LDON	3	34	PDF
LDP	4	33	PDE
VCC	5	32	PDER
RF-	6	31	PDFR
RFOUT	7	30	TBAL
RFIN	8	29	FBAL
C.AGC	9	28	FE-
ARF	10	27	FEOUT
C.ENV	11	26	TE-
C.EA	12	25	TEOUT
CSBDO	13	24	CROSS
BDO	14	23	TEBPF
CSBRT	15	22	VDET
OFTR	16	21	LDOFF
/NRFDET	17	20	VREF
GND	18	19	ENV

2. Block diagram

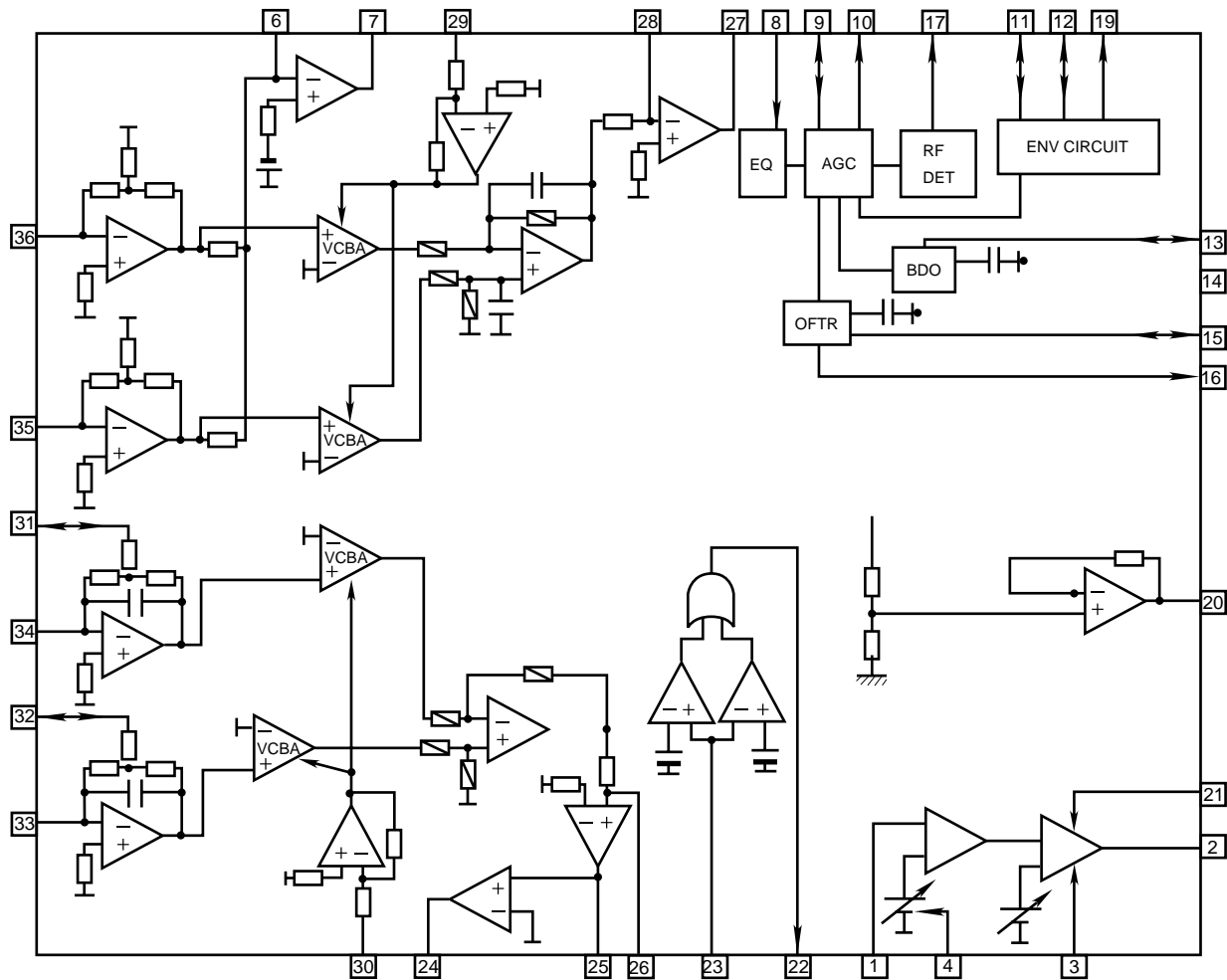

3. Pin function

Pin No.	Symbol	I/O	Function
1	PD	I	APC amp input terminal
2	LD	O	APC amp output terminal
3	LDON	I	APC ON/OFF control terminal
4	LDP	--	Connect to ground
5	VCC	--	Power supply
6	RF-	I	Inverse input pin for RF amp
7	RFOUT	O	RFamp output
8	RFIN	I	RF input
9	C.AGC	I/O	Connecting pin of AGC loop filter
10	ARF	O	RF output
11	C.ENV	I/O	A capacitor is connected to this terminal to detect the envelope of RF signal
12	C.EA	I/O	A capacitor is connected to this terminal to detect the envelope of RF signal
13	CSBDO	I/O	A capacitor is connected to detect the lower envelope of RF signal
14	BDO	O	BDO output pin
15	CSBRT	I/O	A capacitor is connected to detect the lower envelope of RF signal
16	OFTR	O	Of-track status signal output
17	/NRFDET	O	RF detection signal output
18	GND	--	Ground
19	ENV	O	Envelope output
20	VREF	O	Reference voltage output
21	LDOFF	I	
22	VDET	O	Vibration detection signal output
23	TEBPF	I	Input pin of tracking error through BPF
24	CROSS	O	Tracking error cross output
25	TEOUT	O	Tracking error signal output
26	TE-	I	Inverse input pin for tracking error amp
27	FEOUT	O	Output pin of focus error
28	FE-	I	Inverse input pin for focus error amp
29	FBAL	I	Focus balance control
30	TBAL	I	Tracking balance control
31	PDFR	I/O	F I-V amp gain control
32	PDER	I/O	E I-V amp gain control
33	PDE	I	I-V amp input
34	PDF	I	I-V amp input
35	PDBD	I	I-V amp input
36	PDAC	I	I-V amp input

■ TA2068N (IC301) : Rec/PB. amplifier

1. Terminal layout

AGC	1	24	RAIN1
PBO1	2	23	MICSEL
PBNF1	3	22	CDIN1
REC1	4	21	P/R
PBIN1	5	20	OUT1
VREF	6	19	VCC
VSS	7	18	OUT2
PBIN2	8	17	SEL
REC2	9	16	CDIN2
PBNF2	10	15	TAPE
PBO2	11	14	RAIN2
MICNF	12	13	MICIN

2. Block diagram

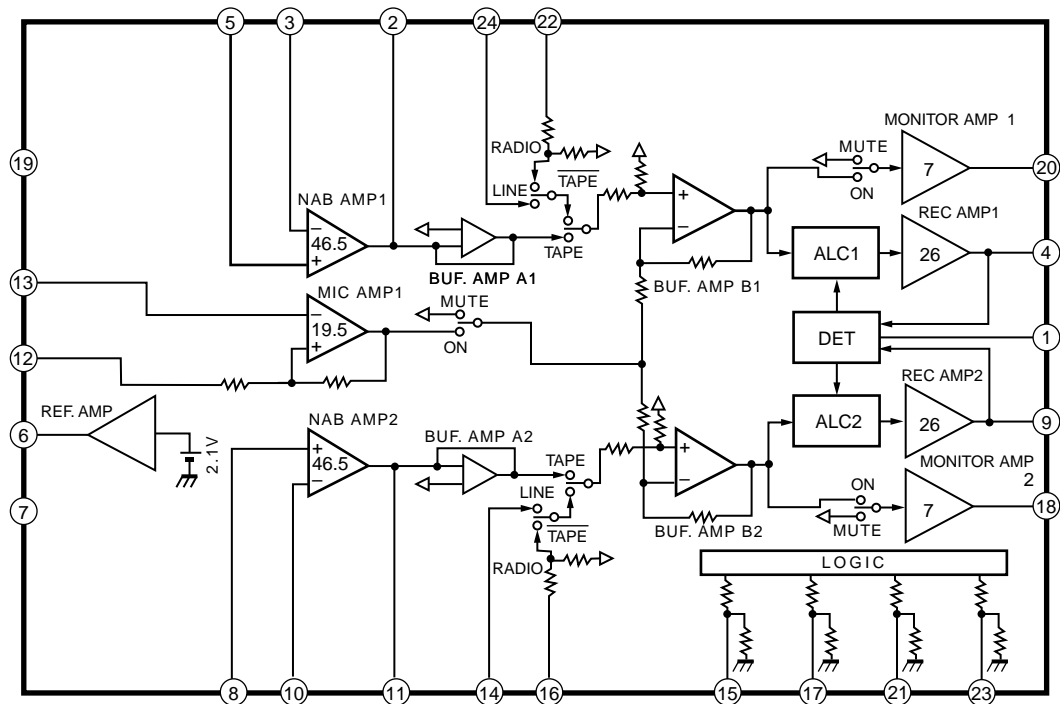

JVC

VICTOR COMPANY OF JAPAN, LIMITED

AUDIO & COMMUNICATION BUSINESS DIVISION

PERSONAL & MOBILE NETWORK B.U. 10-1,1Chome,Ohwatari-machi,Maebashi-city,371-8543,Japan